

A General Equilibrium Model for Regional Economic Development

Paper presented to 2003 EcoMod Conference, 3-5 July 2003, Istanbul, Turkey

Dr Adolf Stroombergen¹ and Dr George Stuart²

Abstract

We describe how a dynamic general equilibrium model designed for analysing regional economic growth strategies is operationalised using systems dynamic software (*i think*). This package is especially suited to models which will be operated by non-economists. It is sufficiently flexible to be able to simulate a wide range of regional growth scenarios, such as:

- different rates of export growth
- changes in tax rates
- industry promotion
- changes in land zoning
- enhanced labour productivity and training
- encouraging population inflows
- raising business confidence
- improving infrastructure

The user interface is by way of tables, graphical inputs, button switches and slider controls. The software can also be linked to *Excel* via a 'dynamic data exchange'. The model output is presented in graphs and tables.

The model incorporates the usual features of a general equilibrium model:

- multi-industry
- production functions with factor substitution
- consumer demand functions
- income and expenditure flows
- exports and imports
- product flows
- population aging, and internal and external migration

1. Model Outline

The KAPHORM model is a small general equilibrium model of the Horowhenua-Kapiti region of New Zealand.³ The region has a population of about 73,000 and is adjacent to the Wellington region which contains New Zealand's capital city.

¹ Chief Economist, Infometrics, Wellington, New Zealand

² Director, Future Impact Ltd, Wellington, New Zealand

³ We are grateful to Tony Rush, chief executive of Enterprise Horowhenua for initiating and arranging funding for development of the model.

The core of the model is a condensed set of estimated regional accounts, comprising an input-output table with 12 or 13 industries, and income-outlay accounts for the household, business and external sectors. There is also a demographic sector that links the supply of labour to the age structure of households and provides a basis for determining transfer payments such as unemployment benefits and old-age pensions from central government.

Locally produced output is sold either to local industries, local households, government, or exported to other regions – whether elsewhere in New Zealand or internationally. Revenue from sales is used to pay for inputs from other local industries, imports from other regions, capital, labour and taxes. Retained earnings are a balancing item.

Income earned by households from wages and salaries is augmented by income from capital (interest and dividends) and government transfers. Household income is allocated to income tax, indirect tax, consumption and savings. Consumption includes locally produced goods and imported goods.

A regional external account balance is calculated by subtracting import payments (made by industries and households) from export receipts and factor income receipts – primarily income earned by local residents who work outside the region.

The model is designed for scenario analysis for regional economic development. It is a high level model that is not designed to simulate the minutia of theoretical microeconomic behaviour at either the industry or household level. Also, is not a forecasting model.

Given its purpose, the model has a number of input panels that contain variables and parameter values which may be altered by the user. In particular:

- Birth, death and migration rates
- The mean rates of tax on household income and business income
- Household savings rate
- Rates of social welfare benefits
- Rates of growth and absolute increments in exports
- The rate of growth in government consumption
- Total factor productivity by industry
- Wage rates by industry
- Labour demand and wage rates outside the Horowhenua-Kapiti region
- Business confidence index.

2. Model Structure

The model is essentially composed of two modules; a demographics module and an economic module that are linked as shown in Figure 1. The demographics module is relatively straightforward, containing simple equations for aging, fertility, mortality and migration. The economics module contains a number of blocks of equations as described below

Production Functions

These equations determine how much output can be produced with given inputs of labour and capital. A standard “constant elasticity of substitution” specification is used. The parameters of the function are based on an assumed labour-capital substitution elasticity is 0.50, although this is irrelevant in most cases as relative factor prices do not change. Each production function is augmented with an industry-specific parameter to capture changes in the rate of total factor productivity.

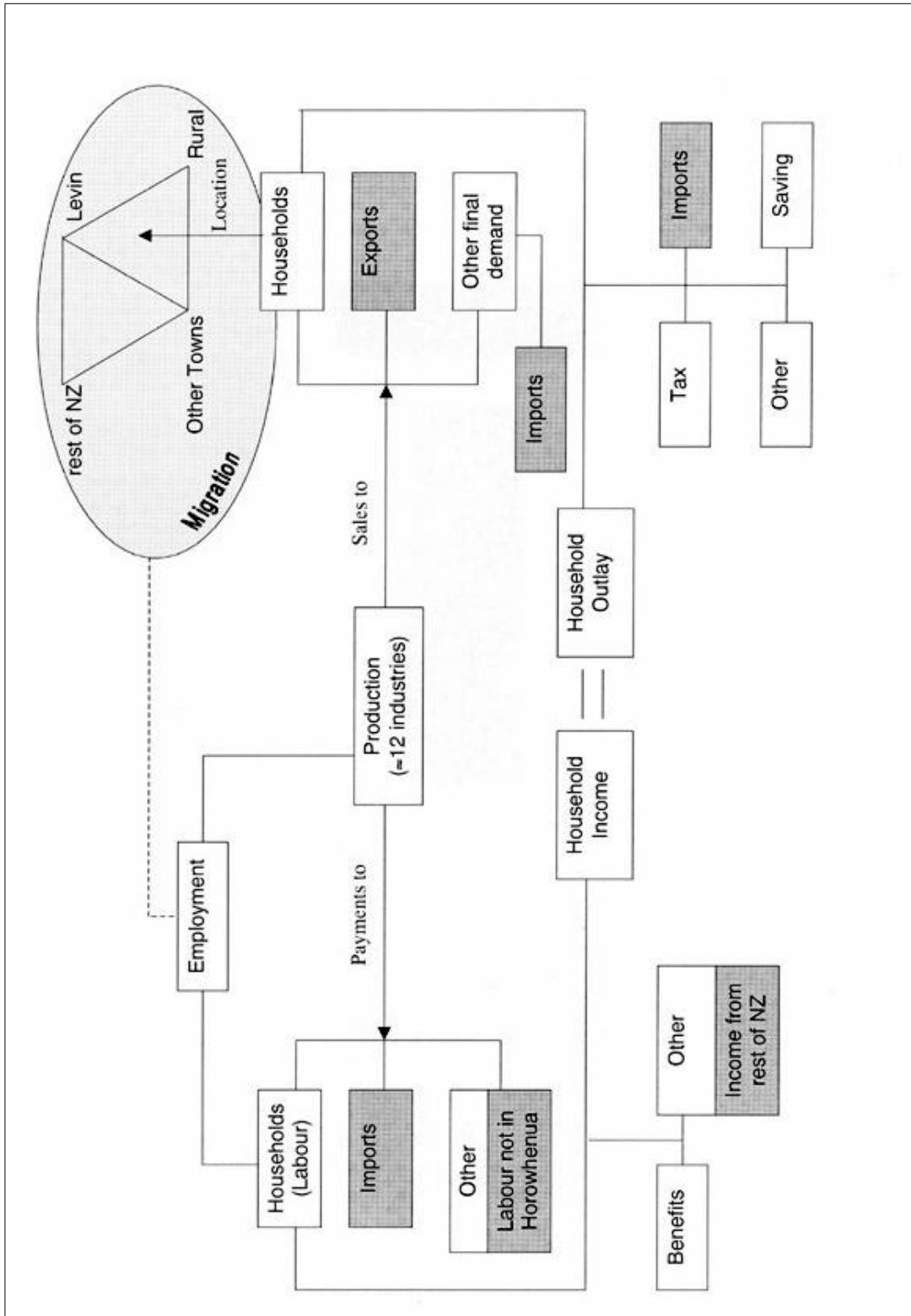

Figure 1: Model Structure

Intermediate Demand

Each industry uses inputs from other industries with fixed technology coefficients. Imports are also used with fixed technology coefficients.

Price Determination

The overall price level is not modelled. The only explicit prices are benefit rates, and real factor prices (wage rates and rental rates) with the latter linked to changes in total factor productivity and the former set exogenously in recognition of the fact that they are determined outside the Horowhenua-Kapiti region. In addition, rental rates adjust in Ownership of Dwellings to balance supply and demand (see below under stock change).

Consumption Expenditure

Consumption is divided into Government Consumption and Private/Household Consumption. The former covers expenditure by local and central government in the Horowhenua-Kapiti region. It is usually set exogenously. Private Consumption is a residual after subtraction of taxes and savings from gross income. Savings are set as proportion of net income, with the proportion being set at the base year (2001) value, adjusted for unanticipated changes in capital income (dividends) received by households. Unanticipated changes arise when the share of profits retained by business versus the share distributed to households is different from the base year allocation. This is further explained in Income-Expenditure Identity below.

Exports

Exports are set exogenously by the model user. Exports constitute one of the main means by which regional gross domestic product may be increased. Note that the definition of exports includes any goods and services sold outside the region, whether overseas or elsewhere in New Zealand, plus any goods and services sold locally to non-residents – mostly tourists.

Stock Change

Demand in any given period is supplied in the first instance by production from the previous period and by imports – where the latter are used in fixed ratios to output or consumption. If this combined supply is insufficient to meet demand, the model will deplete stocks. If total stock depletion still does not satisfy demand, additional importing occurs.

The model will then attempt to rebuild stocks back to their desired level in the following period. It may or may not be successful depending on production capacity. If it is not successful, additional importing may again be required. Thus it may take a number of periods for stocks to regain desired levels. This can lead to volatility in imports and investment.

Stocks in the industry Owner-Occupied Dwellings are determined differently. Clearly it is not possible to import owner-occupied housing services, so once the demand for housing exceeds the supply, the cost of housing (in the form of the imputed rental rate on the housing stock) rises to the point where excess demand is zero. In the following period the normal investment mechanisms act to increase the supply of housing.

Note also, that stocks in the service industries are not stocks in the usual sense as for example, building services and cinema services cannot be stored. For these industries stocks effectively represent short term additional productive capacity, such as excess seating capacity and staffing in the case of cinemas, to cope with month to month changes in demand. If excess capacity is insufficient in the short term, the services are imported; builders from outside the region commute into the region, and consumers visit the cinema in neighbouring regions. Over time new investment occurs to increase local capacity.

Investment

Industry investment is determined by the degree of capacity utilisation as follows (see also Figure 8):

- If expected demand for output exceeds capacity by more than a given percentage K (which varies by industry) then investment is equal to $(K$ plus the rate of depreciation) multiplied by the existing capital stock. However it cannot exceed a given multiple of the previous period's investment. Again this multiple is industry specific and recognises the different rates at which different industries can increase capacity – more slowly in utilities than in say retailing.
- If expected demand for output is less than capacity by more than $K\%$, there is disinvestment to the extent of the difference between K and actual capacity utilisation, but not exceeding (absolutely) the amount of investment required to replace depreciated capital stock. In other words, once a certain level of excess capacity has been reached, worn-out capital is no longer replaced, but no industry can reduce its capital stock by faster than the rate at which it depreciates.
- If capacity utilisation falls between $\pm K\%$, investment is equal to the previous period's investment plus an increment related to the Business Confidence Index. That is, businesses will accept up to a certain level of surplus or deficit capacity before they change their investment behaviour. (Planned enhancements include applying a time limit to this inertia.)

Labour Demand

Industry demand for labour essentially follows the same rules as the demand for investment, except that in the case of too much surplus capacity it is possible to shed labour. However, the rate of labour shedding is subject to industry-specific maxima. This is to simulate the inertia effect of employment contracts and related institutional impediments to rapid staff reduction.

Income-Expenditure Identity

Total expenditure on domestically consumed final demand must be equal to the income generated by labour, capital, indirect taxation and net capital inflows. Similarly, income and expenditure flows must balance between businesses, households, government, outside (other New Zealand and foreign) residents and capital financing.

Because of the lag between when income is earned (when output is produced) and when income is spent, industries may experience unexpected changes in profit. This means that there may be a discrepancy between the income and expenditure side of the regional accounts in any given " dt " (where dt is usually set at $\frac{1}{4}$ of a standard model time period, which is 3 months). In reality this discrepancy cannot occur because regional income must equal regional expenditure – it is an accounting identity. In fact what would happen is that businesses and/or households would cover the difference by borrowing and lending, which would see a change in net capital inflows into or out of the region. The model treats this a self-balancing residual and keeps track of it in the series *I'E Dif*, which is presented in the Miscellaneous graph pad.

Unanticipated inflows or outflows of this sort are reflected in the proportion of profits that are remitted to households, on the argument that household consumption has the largest weight in regional GDP and because the split of household income and expenditure between what is earned and spent in Horowhenua-Kapiti and what is earned and spent elsewhere (mainly Wellington), probably contains an error of at least 2% of regional GDP.

Industry Classification

There are 12 industries identified in the model as listed below. Industry definitions are according to the Australian and New Zealand Standard Industrial Classification (ANZSIC). There is a 13th industry, the reserved industry, which the user can define from scenario to scenario. This is explained below.

	Name
1	Horticulture and Fruit Growing
2	Pastoral Farming
3	Other Primary including Forestry and Mining
4	Food Processing, Beverages and Tobacco
5	Textiles, Clothing and Footwear
6	Manufacturing not elsewhere included and Construction
7	Electricity, Gas and Water
8	Trade, Accommodation, Restaurants and Leisure Services
9	Transport and Communication
10	Business Services
11	Personal, Community and other Services
12	Ownership of Owner-Occupied Dwellings (imputed)
13	'Reserved' industry

3. The Model's User Interface

The Home Screen

Figure 2 shows the entry page or home screen for the KAPHORM model as seen by the model user on their computer. Each panel is an icon, clicking on which will bring up information about that panel. For example the top left hand panel for the 'Kapiti Coast District Council' contains information about the council and where it is located. The panel with the graph on it enables the user to go straight to the model's output, as explained below. The panel labelled 'Industry' brings up the options available to the user to change various assumptions and coefficients relating to industry characteristics. This panel and those for 'Demographics', 'Households' and 'Reserved Industry' are explained in the following sections.

The panels on the right hand side provide various short-cuts for the user to reset any coefficients and variables that might have been changed, back to their default values. It also enables all graphs and tables to be cleared, which saves on storage requirements.

The Demographics Screen

Figure 3 shows input screen for the demographic inputs. The model encompasses five population locations representing the total population of the region. The locations are Paraparaumu/Raumati, Other Towns Kapiti, Levin, Other Towns Horowhenua and Rural areas. Population changes are considered in five-year age groups using national age-specific fertility and mortality rates for the year 2001, with migration between the different locations as recorded between 1996 and 2001 by the New Zealand population census. Migration rates for people arriving at, and departing from each of the locations are similarly derived.

The model allows the user to change the fertility and mortality rates for the whole region (as shown by the slider controls in Figure 3) and to change the migration rates for each location. These latter changes are effected by clicking on the panels for the five population centres on the left hand side of Figure 3.

Employment within the model is considered at a regional level - it does not go down to the level of individual locations.



Figure 2: The KAPHORM Model Home Screen

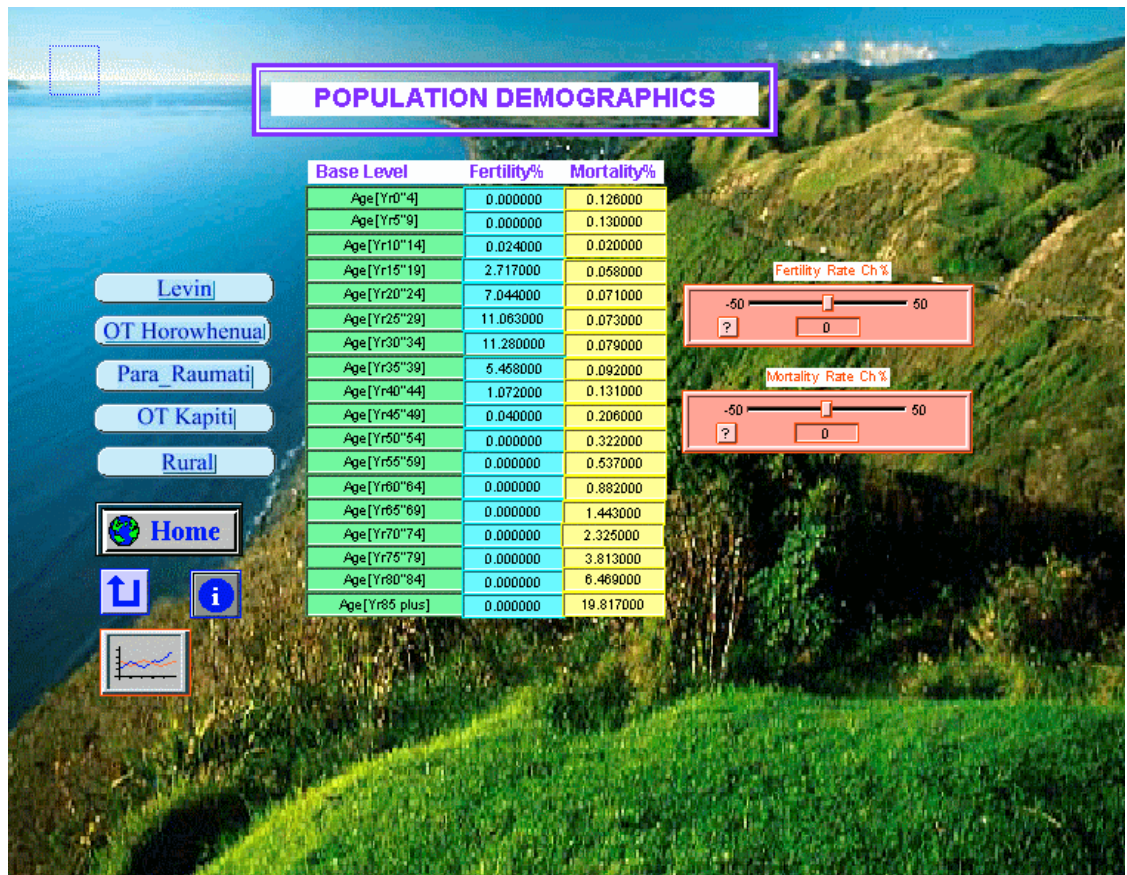

Figure 3: The Population Demographics Input Screen

The Households Screen

Figure 4 shows the screen for changing inputs related to the model's household sector. The various input panels are described below

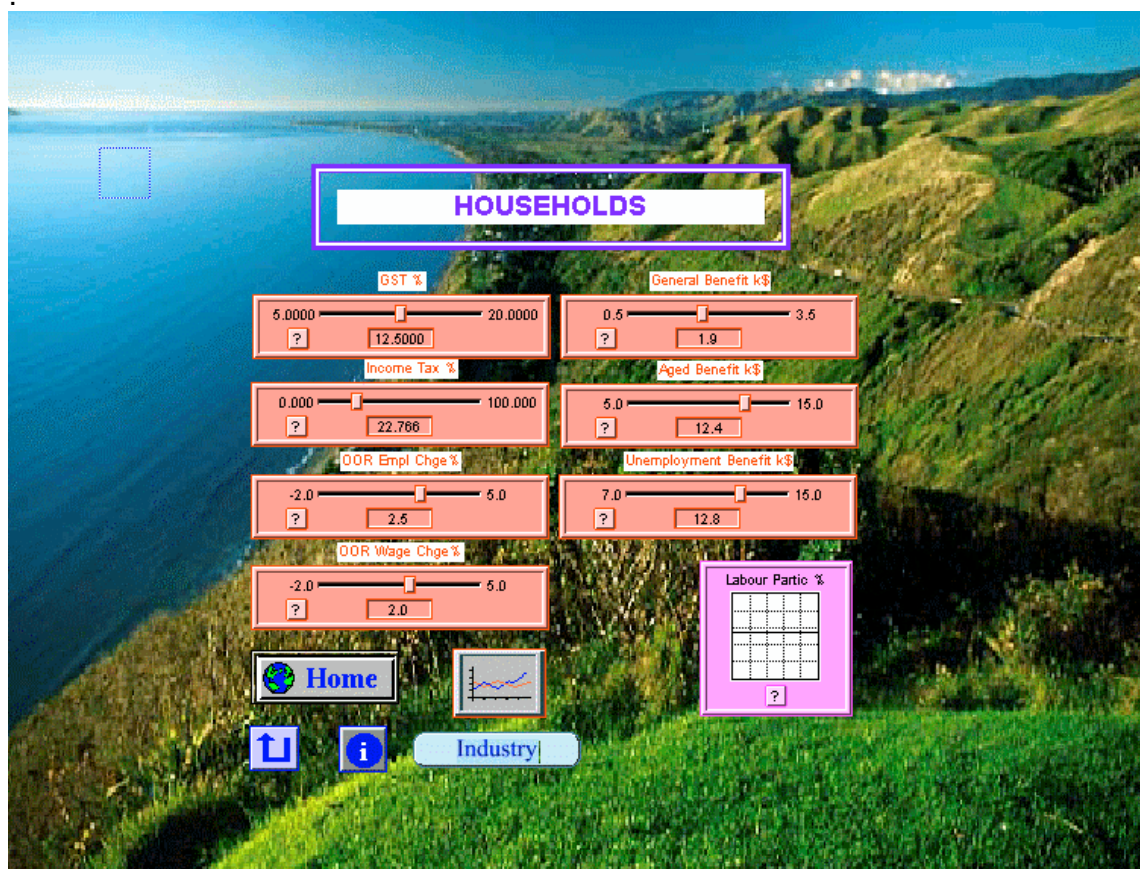

Figure 4: The Households Input Screen

GST

Good and services tax at the statutory rate of 12.5%, is levied on goods and services purchased by households. Note that some goods and services such as rent do not attract GST. Also the exemption of financial services from GST means that some GST is paid by this industry. This is captured implicitly in the indirect tax coefficient for this industry.

Income Tax

The average rate of personal income tax in 2001 across all households in the region.

Unemployment Benefit

The mean rate of unemployment benefit taking into account dependent spouses and children.

Aged Benefit

The mean rate of New Zealand Superannuation taking into the account the mix of married and single people.

General Benefit

Other benefits such as the Sickness, Invalids and Domestic Purposes Benefits, averaged over all persons not receiving the Unemployment Benefit or NZS.

OOB Employment Change

Out-of-region employment change – the expected rate of change in employment in regions that are neighbours of Horowhenua – Kapiti Coast, and in which residents of Horowhenua – Kapiti may be employed. In essence this means the Wellington region.

OOB Wage Change

Out-of-region wage change – the expected rate of change in wage rates in regions which are neighbours of Horowhenua – Kapiti Coast, and in which residents of Horowhenua – Kapiti may be employed, again primarily Wellington.

Labour Participation

The labour force participation rate as defined by Statistics New Zealand – essentially people aged 15 or more who are either in employment or available and actively seeking employment.

The Industry Screen

Figure 5 shows the screen for changing inputs that relate to the model's business sector. The various input panels are described below.

Government Growth

The expected rate of growth in government consumption. Note that this refers to current (not capital) spending by local and central government on education, health, administration and so on. It does not include transfer payments such as social welfare.

Business Confidence Index

This affects investment intentions in the short term. A value of 100 is neutral and the range of values goes from 0 to 200. The degree of sensitivity of the model's results to this parameter depends on the values of the other exogenous variable and constraints.

Corporate Tax

The statutory rate of company tax which is 33%. Note that although the effective tax rate is often less than 33%, data is not available at a regional basis to allow for this degree of refinement.

Wage Rates

These are industry-specific wage rates measured in thousands of dollars per annum. In the model they change with productivity improvements unless altered by the user.

Total Factor Productivity

Total factor productivity refers to the rate of change in the efficiency with which inputs of labour and capital (buildings, machinery and equipment) are used in production.

Export Growth and Export Increment

The expected rate of change in exports by industry, and future exports in absolute dollar terms (\$m) which may be set instead of, or as well as the growth rate.

Indirect Tax

These are industry specific tax or subsidy rates expressed as a percentage of industry sales. They include for example import tariffs, local government rates, road user charges and excise taxes on tobacco, alcohol and motor spirits.

Land Use

Land use is the amount of each of seven types of land available. (As at the time of writing the data for this module is incomplete.)

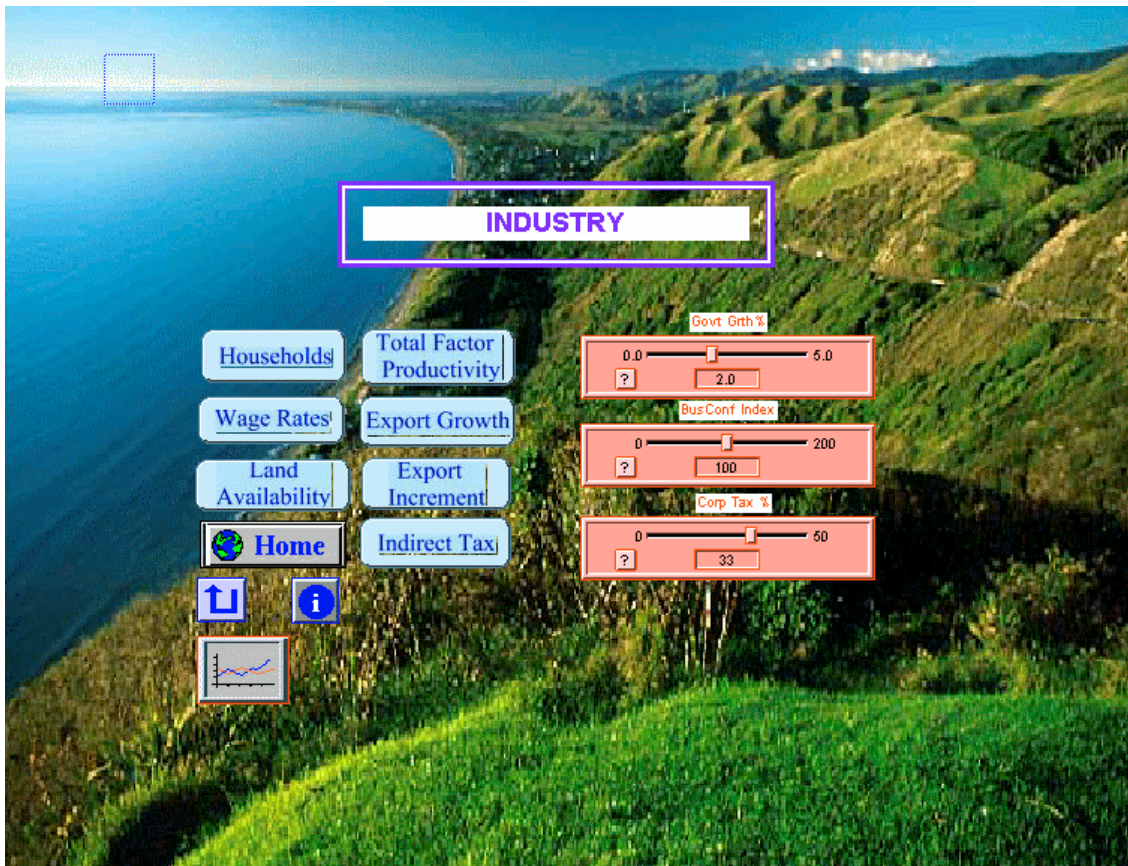

Figure 5: The Industry Input Screen

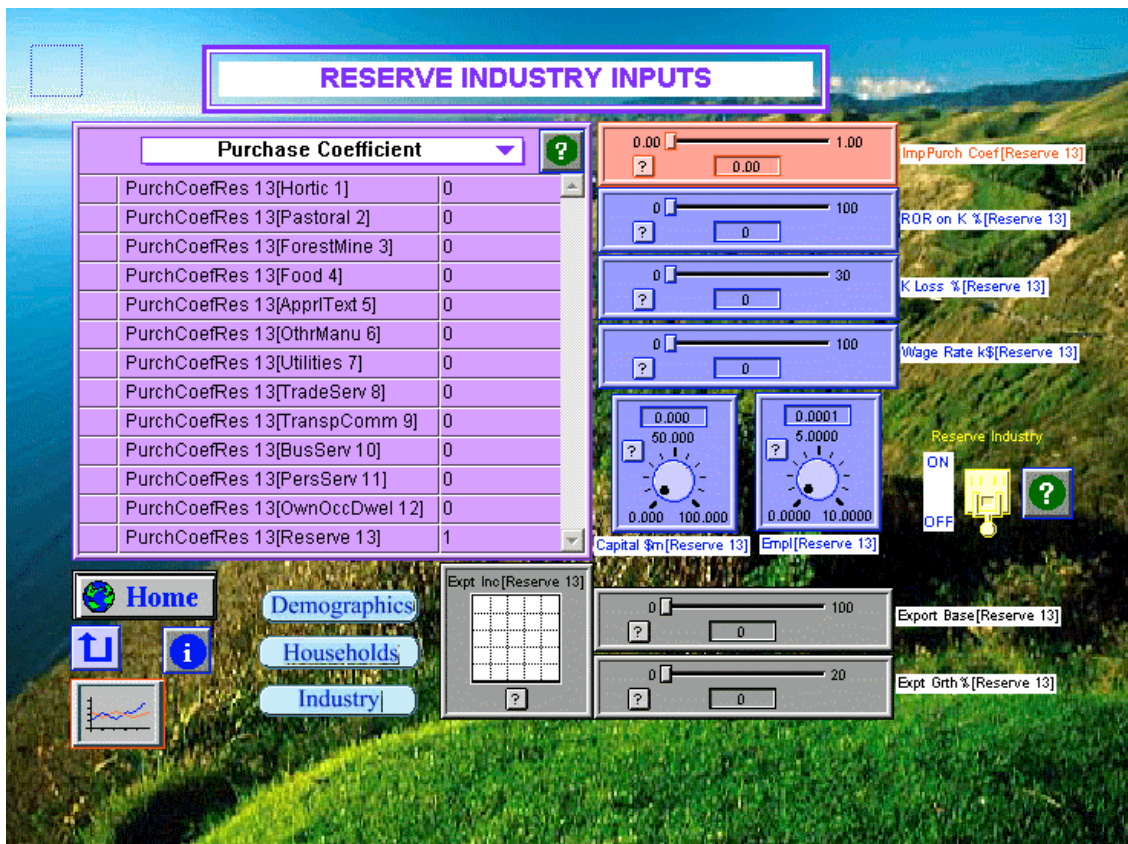

Figure 6: The Reserve Industry Screen

The Reserve Industry Screen

The panels by which the user may enter the characteristics of a new exporting industry are shown in Figure 6. In essence the user needs to calculate the purchase vector of an input-output table. The various panels are as follows:

Purchase coefficient

This is a 13x1 array that shows what the Reserve industry purchases from every other industry (including itself if need be), expressed as a percentage of gross output. Note that for gross output we typically use sales.

Import Purchase Coefficient

The proportion of the Reserve industry's inputs that cannot be purchased from businesses in Horowhenua – Kapiti Coast, expressed as a proportion of gross output.

Rate of Return (ROR) on Capital

The percentage rate of return on capital prior to depreciation and income tax. It may be approximated by EBITD/Fixed Assets.

Capital Loss

The rate of depreciation of the capital stock in the Reserve industry, expressed as a percentage.

Wage Rate

The cost of labour in the Reserve industry, measured in thousands of dollars per annum.

Capital Stock

The initial value of the capital stock in the Reserve industry expressed in \$million.

Employment

The initial value of employment in the Reserve industry expressed in thousands of full time equivalent jobs.

Export Base

The initial value of exports from the Reserve industry expressed in \$m

Export Growth

The expected rate of change in exports by the Reserve industry.

Export Increment

Where it is desired to set future exports from the Reserve industry in absolute dollar terms (\$m) instead of, or as well as in growth rates, this panel should be used.

4. Output Graphs

The model's output is extremely comprehensive, covering the standard collection of macroeconomic and industry variables. Figure 7 shows the standard output screen which contains the summary graph pad. This pad contains a number of output series as described below.

GDP

Gross domestic product (for the in Horowhenua – Kapiti Coast region). This can be defined from the expenditure side and the income side:

Expenditure: household consumption + government consumption + gross investment + stock change + exports – imports.

Income: Wages and salaries to labour, gross return on capital and indirect tax payments by industry.

Total Exports

The sum of exports from the 12/13 industries.

Imports

Total imports for household consumption, government consumption, investment, stock change and intermediate inputs by industries.

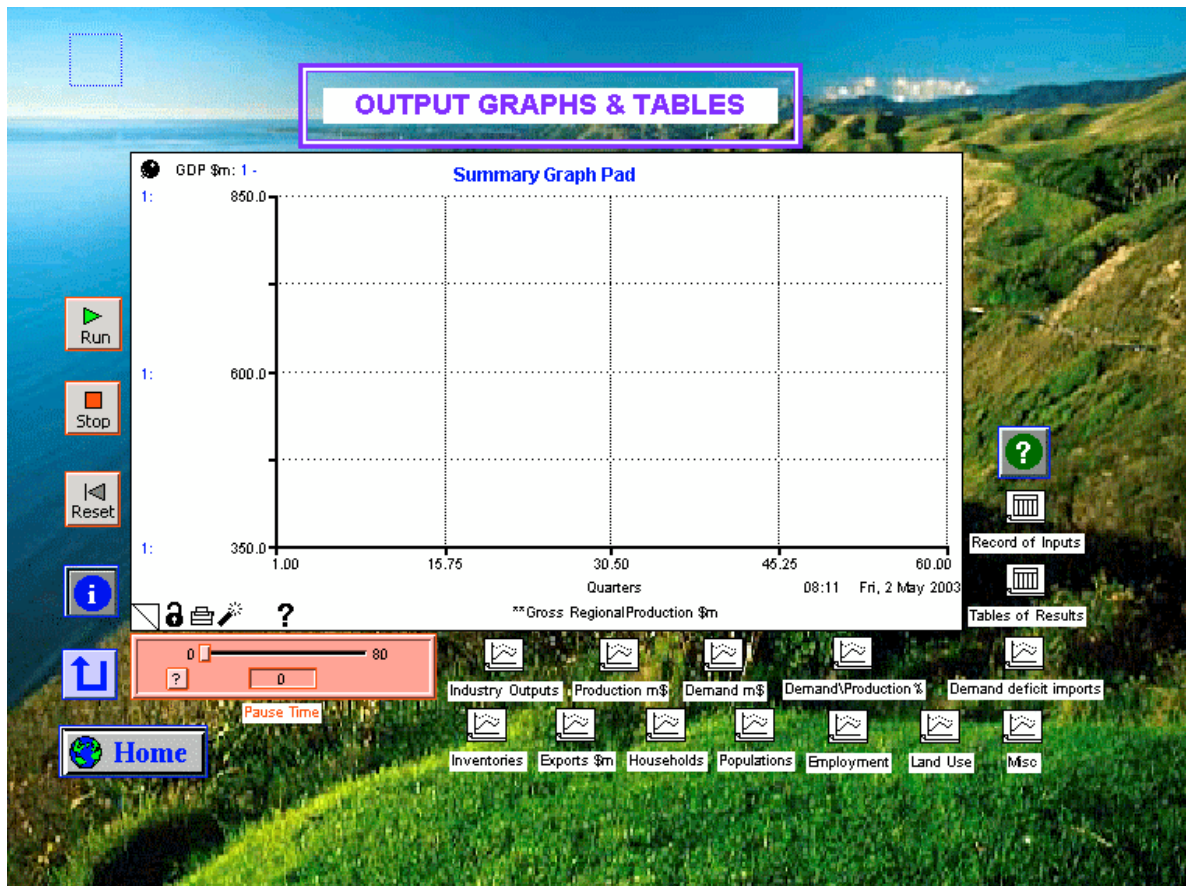

Figure 7: The Summary Graph Pad Screen

Total Employment

Employment summed over all industries.

Labour Force

The labour force is as defined by Statistics New Zealand – essentially people aged 15 or more who are either in employment or available and actively seeking employment.

Total Employment / Labour Force

The ratio of total employment to the labour force, showing the proportion of the labour force who are employed.

Unemployment Benefit Paid

The value of unemployment benefits paid to unemployed people.

Total Welfare

The total value of welfare benefits (unemployment, New Zealand Superannuation and other benefits) paid to households.

Household Gross Income

The total value of household income from all sources – wages and salaries, self-employment income, dividends, interest, etc, and social welfare benefits.

Household Net Income

Equal to household gross income less income tax payments.

Household Spending

Equal to household net income less savings.

Government Consumption

Expenditure by local and central government on education, health, administration and so on. It does not include transfer payments such as social welfare.

Total Investment

Gross investment summed over all industries.

Total Population

The total population in the Horowhenua – Kapiti Coast region.

GDP per Capita

GDP divided by total population.

GDP Growth

The percent per annum growth in gross domestic product, expressed as an annualised rate calculated over a four quarter moving average.

GDP per Capita Growth

The percent per annum growth in gross domestic product per capita, expressed as an annualised rate calculated over a four quarter moving average.

The remaining graph pads relates to industry variables such as employment, output, demand, production, and so on. There is also a pad for population which has graphs for population by sub-region and by age

5. Setting up scenarios

Most of the user input panels should relate directly to the types of issues that users may wish to investigate. For example:

- higher exports from the food processing industry,
- more employment opportunities in Wellington,
- fewer young adults leaving Kapiti-Horowhenua,
- longer life expectancies,
- more immigration of pension-age people.

A more difficult scenario is likely to involve the Reserve Industry. In the example below we illustrate what information is required and how the model should be set up. Essentially what is needed is the column of an input-output table, so total revenue must be exactly matched by total expenditure, including profit.

Example: Establishment of a new industry which grows and exports blue tulips, with an initial annual value of \$10m..

Input	Value \$m	Value to go in Reserved Industry panel	Explanation
Other Primary	1.5	0.15	advice from agricultural consultants
Energy & Water	0.2	0.02	irrigation
Transport & Com.	0.6	0.06	distribution of product to airports
Business Servs.	0.5	0.05	legal, financial & insurance services
'Reserved' industry	0.1	0.01	bulbs purchased from itself
Sum of local intermediate inputs	2.9		
Imports	3.8	0.38	biotechnology technology expertise, overseas travel and marketing
Labour	1.2	Employment: 0.024 Wage Rate: 50	24 FTE @ \$50,000 average wage. Note that employment and wage rates are entered in thousands.
Capital	1.8	Capital: 5.0 ROR: 36.0	36% rate of return on capital stock valued at \$5m.
Total Expenditure	10.0	Export Base: 2.5	The model's period is a quarter, so output should be divided by 4.

There are two other items of information required in the Reserve Industry panels:

1. A depreciation rate for the capital stock.
2. Projected future export levels, either as an annual growth rate or as absolute quarterly values.

The user should then click on the Reserve Industry switch so as to move it to the ON position – see Figure 6. Failure to do this will not prevent the model reading the input panels, but the output will be nonsense. This is because the model uses certain default values in the various Reserve Industry arrays, not all of which are automatically overridden by inputting the above data.

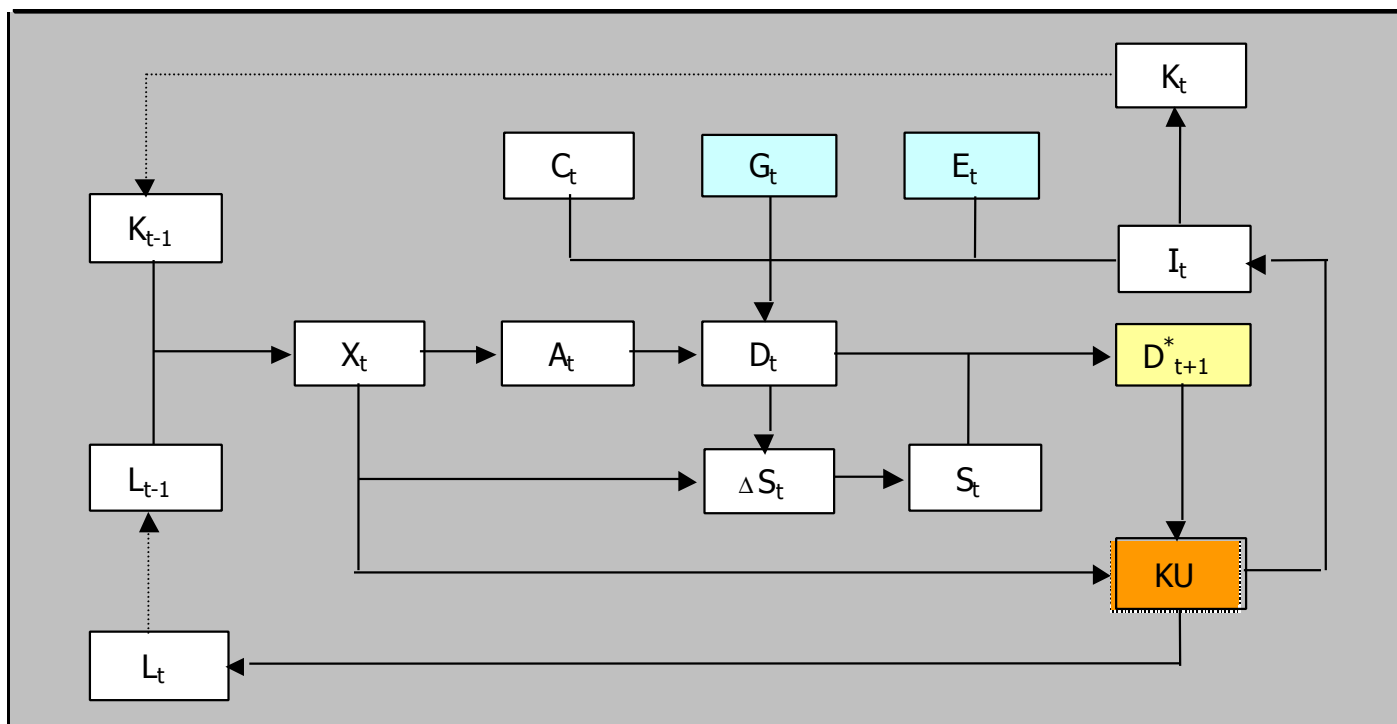

Figure 8: Outline of KAPHORM Production and Investment Dynamics

Production (X) is based on capital (K) including land, and labour (L) installed in the previous period. This is used to meet demand (D) stemming from private consumption (C), government consumption (G), Exports (E) and Investment (I). Any surplus/deficit is added to or subtracted from stocks (with additional imports if necessary). Private consumption is determined endogenously by the model (not illustrated), government consumption and exports are exogenous, and investment is determined by the model as follows. Producers form expectations about demand in the next period (D*) on the basis of demand in the current period. These expectations are compared with current production in form of a capacity utilisation index (KU). The value of KU drives the decision on how much to invest and how much additional labour to hire. Investment is added to the existing capital stock, after allowing for depreciation, and the cycle begins again. Further details are described in the section on the equation blocks.